



# LDI H-FP-1550-15P

## 1550nm 15mW FP LASER DIODE MODULES

These laser diode modules are high stability FP laser-diode modules with single-mode fiber pigtails. These modules are optimal 1550nm 15mW light sources for high-speed optical communication systems and measuring instruments.

### Absolute maximum ratings

LD forward current, $I_f$	150mA
LD reverse voltage, $V_{r1}$	2V
PD reverse voltage, $V_{rd}$	30V
Operating case temperature, $T_c$	-20 ÷ +50°C
Storage temperature, $T_{stg}$	-30 ÷ +60°C

### Electrical / optical characteristics (SM, T=25°C)

Parameter		Min.	Typ.	Max.	Unit	Test conditions
Wavelength	$\lambda$	1520	1550	1580	nm	CW, P=15mW
Threshold current	$I_{th}$	5	10	15	mA	CW
Operating current	$I_{op}$		120	140	mA	CW, P=15mW
Operating voltage	$V_{op}$		1.1	1.5	V	CW, P=15mW
Slope efficiency	$\eta$	0.1	0.16	0.2	mW/mA	CW, P=15mW
Spectral width	$\Delta\lambda$		10	12	nm	CW, P=15mW, FWHM
Rise and fall times*	$t_r, t_f$		0.3	0.5	nc	P=15mW, 10-90%
Monitoring output current (PD)	$I_m$	1	2	3	mA	CW, P=15mW, $V_{rd}=5V$
Capacitance (PD)	$C_t$		10	20	pF	$V_{rd}=5V, f=1MHz$
Tracking error*	$E_r^{**}$		0.6	0.8	dB	CW, P=15mW, $I_m=const, T_c=-20\div+50^\circ C$

\* LDI FP-1550-15P-W(H)

\*\*  $E_r = \text{MAX} |10\log (P_f / P_{f 25^\circ C})|$

### Ordering information

## LDI H-FP-1550-15P-X-SM-X

Case type: **BH, T2**

Connector type: **FC/UPC, FC/APC, N** – without connector

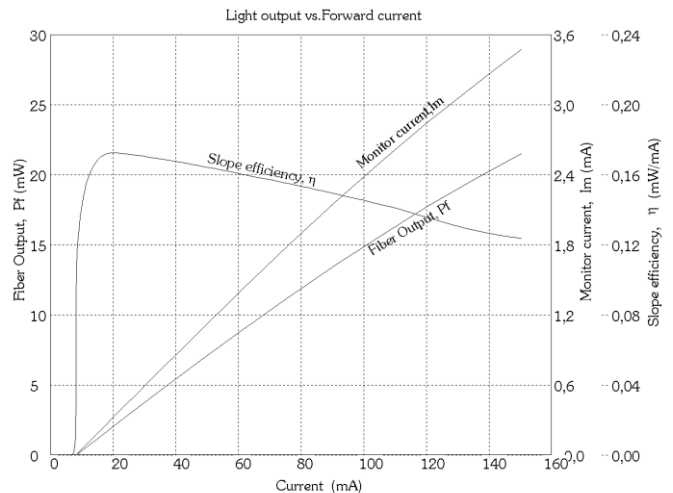
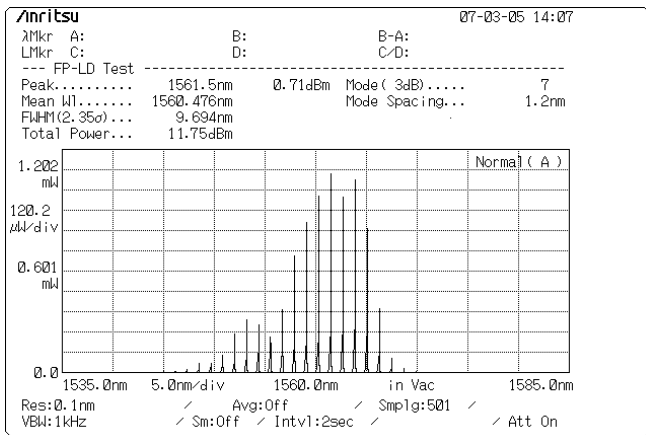

**ATTENTION: ELECTROSTATIC SENSITIVE DEVICES**

Output Power vs. Turn-On Time

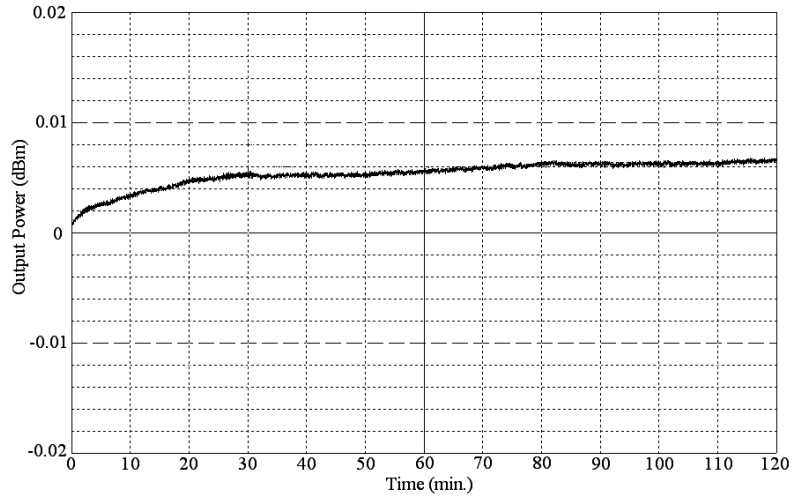

PACKAGE DIMENSIONS (UNIT:mm)

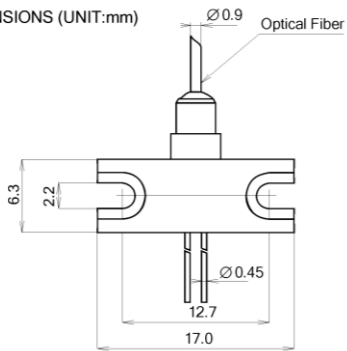

PIN Assignment (Bottom View)

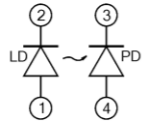
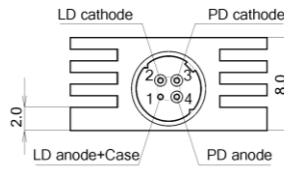

BH

PACKAGE DIMENSIONS (UNIT:mm)

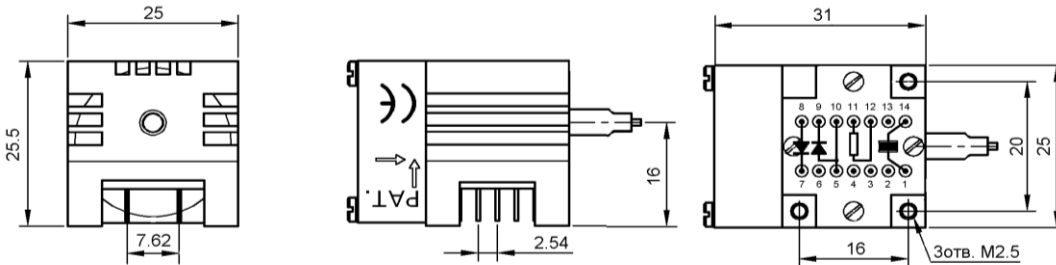

- 1. Cooler anode
- 2.
- 3.
- 4.
- 5. Laser anode
- 6.
- 7. Photodiode cathode
- 8. Photodiode anode
- 9. Laser cathode
- 10. Laser anode
- 11. Thermistor
- 12. Thermistor
- 13.
- 14. Cooler cathode

T2

Thermistor:  $R_t = 10000 \exp\left(\frac{1}{T+273} - \frac{1}{298}\right)$  Cooler:  $I_{max} = 600\text{mA}$   $V_{max} = 3.5\text{V}$  Fan: DC12V=0.5W